



Technology Overview

microQ[®]

portable digital audio engine



Mobile Phones



Music Players



Earphones



UMPCs

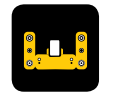

Docking Stations

About microQ[®]

microQ is a compact, modular and highly efficient software digital audio engine enabling polyphonic ringtones, 3D game sound and enhanced music playback with multiple effects for mobile devices. This world-leading mobile audio technology represents the culmination of over 20 years of PC host and DSP audio software development by QSound Labs, Inc.

Product Suite

Unmatched by any single vendor, microQ's modular audio suite consists of the following major components:

mQSynth™ Polyphonic Wavetable Synthesizer

mQSynth plays polyphonic ringtone files, game music as well as interactive real-time sound events using digital wavetable instruments. mQSynth's QSound Realtime Ringtone Remixer (QR3™) re-authors non-optimized content on the fly to produce consistent, distortion-free output.

mQ3D™ Positional 3D Audio Engine

mQ3D Positional places multiple sounds independently in 3D space for interactive gaming. Applicable to arbitrary streams or mQSynth synthesizer channels using native or custom instruments and sound effects. Optional: QEM™ environmental modeling (reverberation).

mQFX™ Digital Effects

The mQFX suite enhances the music listening experience with:

QSound Spatial Enhancements

- **QXpander**® 3D stereo sound stage expansion.
- **QVerb**™ digital reverberation effect.

QEQ Spectral Enhancements

- **QSizzle**™ dynamic high-frequency enhancement.
- **QRumble**™ dynamic low-frequency enhancement.
- **QLoudness**™ Fletcher-Munson equalization adjustment.
- **QEQ** static multi-band equalization.

QVolume

- **QDRC**™ dynamic range control.
- **QLimiter**™ anti-saturation dynamic range control.



The microQ Competitive Edge

- Industry leading, ARM® optimized
- Proven track record and established brand recognition
- Replaces dedicated hardware music synthesizer
- Single-vendor full audio solution:
 - Simplifies integration
 - Saves platform resources
- Selectable, scalable modular components for easy implementation
- Small memory footprint
- High efficiency processing
- Supports earphones and speakers
- Tunable 3D for all narrow geometry speaker configurations

Platforms and Implementations

microQ is written in highly-optimized C++ using fixed-point math, featuring the combination of small footprint and high efficiency that is the hallmark of QSound audio platforms. An optional C interface is also available.

microQ is currently available for DSP and RISC architectures running Linux, Symbian OS®, Nokia® Series 60, and Microsoft® Windows Mobile.

- ARM7™ / ARM9™ / ARM11™ processors
- Marvell® PXA300 / PXA310
- Qualcomm® MSM 6xxx / MSM 7xxx
- Infineon® MP-E
- CEVA® Teak™ / Teak Lite™ DSP cores
- AMD® Imageon™
- Tensilica® HiFi 2 Audio Engine
- TI® OMAP™

microQ can be implemented at various system levels, e.g. within a driver, as a plug-in, or as a user application, and can be provided in the form of object code, or custom ported by QSound Labs to suit your specifications.

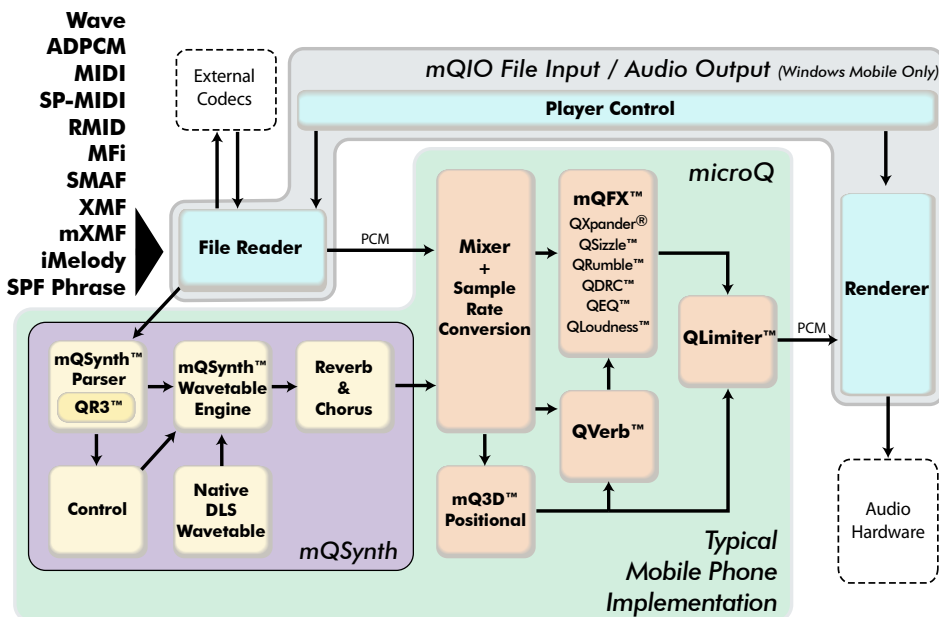

ARM® - QSound® Collaboration

"After evaluation of the QSound microQ technology, we found it offered the best combination of audio quality, performance and memory usage, resulting in a highly competitive solution.

In addition, the modular, component-based architecture creates a flexible solution which addresses the audio requirements of mobile handsets in a more scalable fashion."

ARM™
Lance Howarth
General Manager
Embedded Software

Support for APIs and Standard Formats

microQ renders polyphonic sequenced content (MIDI, SP-MIDI, XMF, mXMF, iMelody, MFi v4.0, SMAF-MA2/MA3/MA5/MA7 with LED, Vibration and .SPF Phrases) with its native wavetable synthesizer sample set or by using custom downloadable instrument sounds (DLS, DLS2.0, Mobile DLS).

microQ plays multiple common linear and compressed formats (WAV, PCM, ADPCM).

microQ API support: Vodafone® VFX, JSR-135, JSR-234, OpenSL ES™.

Contact Us

QSound Labs, Inc.

400 - 3115 - 12th Street NE
Calgary Alberta Canada T2E 7J2

Tel: +1-403-291-2492

Fax: +1-403-250-1521

Email: info@qsound.com

www.qsound.com

