



## About microQ<sup>®</sup>

microQ is a compact, modular and highly efficient software digital audio engine enabling polyphonic ringtones, 3D game sound, and enhanced music playback with multiple effects for mobile devices.

microQ represents the culmination of over 15 years of PC host and DSP audio software development and product deployment by QSound Labs, Inc., a world leader in sonic innovation.

## Product Suite

Unmatched by any single vendor, microQ's modular audio suite consists of the following major components:

### mQSynth™ Polyphonic Wavetable Synthesizer

For ringtones and background music in interactive applications such as games, mQSynth plays musical scores contained in performance files (MIDI and similar formats) using digital sample-based instruments.

### mQ3D™ Positional 3D Audio Engine

mQ3D Positional places multiple sounds independently in 3D space for interactive gaming. Applicable to arbitrary streams or mQSynth synthesizer channels using native or custom instruments and sound effects. Optional: QEM™ environmental modeling (reverberation).

### mQFX™ Digital Effects

Enhancing the music listening experience, the mQFX suite includes:

- **QXpander<sup>®</sup>** 3D stereo sound stage expansion.
- **QSizzle™** dynamic high-frequency enhancement.
- **QRumble™** dynamic low-frequency enhancement.
- **QVerb™** reverberation (reflecting sound like echoes).
- **QCompressor™** dynamic range control.
- **QEqualizer™** static multi-band equalization.
- **QLimiter™** anti-saturation dynamic range control.
- **QLoudness™** Fletcher-Munson equalization loudness curve.

### QXpander<sup>®</sup>

Proprietary **QXpander** 3D spatial processing literally adds new dimension to music playback, expanding the sound stage beyond the physical limitations of speaker locations, and expanding the acoustic image outside the listener's head when listening with earphones.



## The microQ Competitive Edge

- *Industry leading:*
  - ARM optimised and qualified
- *Proven track record and established brand recognition*
- *Replaces dedicated hardware music synthesizer*
- *Single-vendor full audio solution:*
  - Simplifies integration
  - Saves platform resources
- *Selectable, scalable modular components for easy implementation*
- *Small memory footprint*
- *High efficiency processing*
- *Supports earphones and speakers*
- *Tunable 3D for all narrow geometry speaker configurations*



## Platforms & Implementations

microQ® is written in highly-optimized C++ using fixed-point math, featuring the combination of small footprint and high efficiency that is the hallmark of QSound audio platforms. An optional C interface is also available.

Modular, scalable components make microQ readily adaptable to any target environment, with the requirement for platform-specific code reduced to input and output interfaces.

microQ is currently available for DSP and RISC architectures running Linux, Symbian OS® 7.0s+, Nokia® Series 60, and Microsoft® Mobile.

- ARM® 7, ARM® 9
- ARM® 9E, ARM® 11 (Optimized by ARM®)
- CEVA-Teak™ & Teak Lite™ DSP cores
- Infineon APOXI® Appl. Framework
- Qualcomm® MSM 6xxx/MSM 7xxx
- Tensilica® Xtensa®
- ATI Imageon™
- TI® OMAP™

microQ can be implemented at various system levels, e.g. within a driver, as a plug-in, or as a user application.

microQ can be provided in the form of object code, or custom ported by QSound Labs to suit your specifications.



- Wave
- ADPCM
- MP3\*
- MIDI
- SP-MIDI
- RMID
- MFi
- SMAF
- XMF
- mXMF
- iMelody
- SPF Phrase

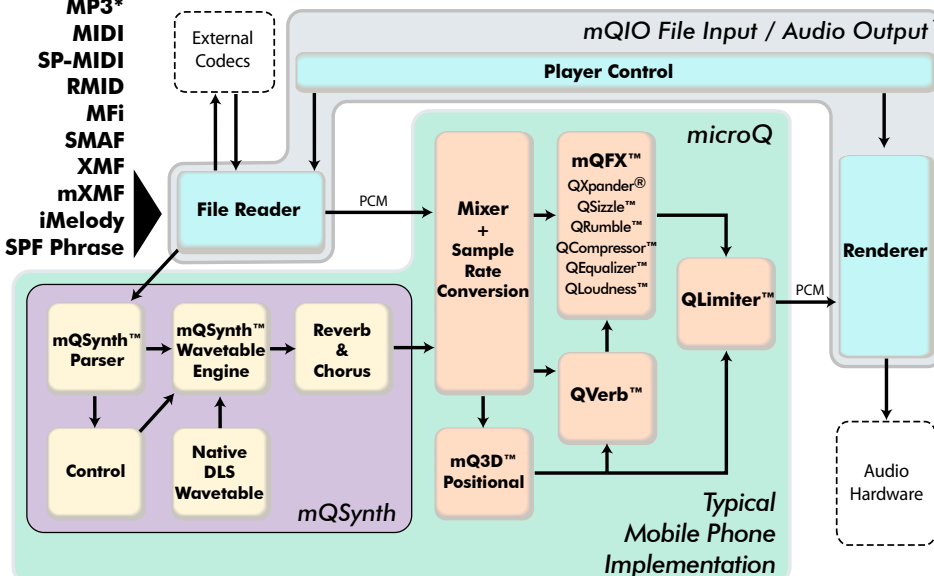

\* On Marvell XScale parts

<sup>1</sup> mQIO is an optional component and is not available for all operating systems

## ARM's Audio Technology Partner of Choice

"After evaluation of the QSound microQ technology, we found it offered the best combination of audio quality, performance and memory usage, resulting in a highly competitive solution.

In addition, the modular, component-based architecture creates a flexible solution which addresses the audio requirements of mobile handsets in a more scalable fashion."

**ARM**  
Lance Howarth  
General Manager  
Embedded Software

## Support for API's & Standard Formats

microQ renders polyphonic sequenced content (MIDI, SP-MIDI, XMF, iMelody, MFi v4.0, SMAF-MA2/MA3/MA5 with LED, Vibration and .SPF Phrases) with its native wavetable synthesizer sample set or using custom downloadable instruments (DLS, DLS 2.0, Mobile DLS).

microQ plays multiple linear and compressed digital audio formats (WAV, PCM, ADPCM, MP3\*). \*On Marvell parts

microQ API support: Vodafone® VFX, JSR-135, JSR-234

## Contact Us

### QSound Labs, Inc.

400 - 3115 - 12th Street NE  
Calgary Alberta Canada T2E 7J2

Tel: +1-403-291-2492

Fax: +1-403-250-1521

Email: info@qsound.com

Visit our website for a complete list of regional sales representatives in your area.

[www.qsound.com](http://www.qsound.com)

