

OEM Guide To

QSurround[®] QSound[®] Virtual Audio Rendering for Surround Formats

QSound Labs, Inc.

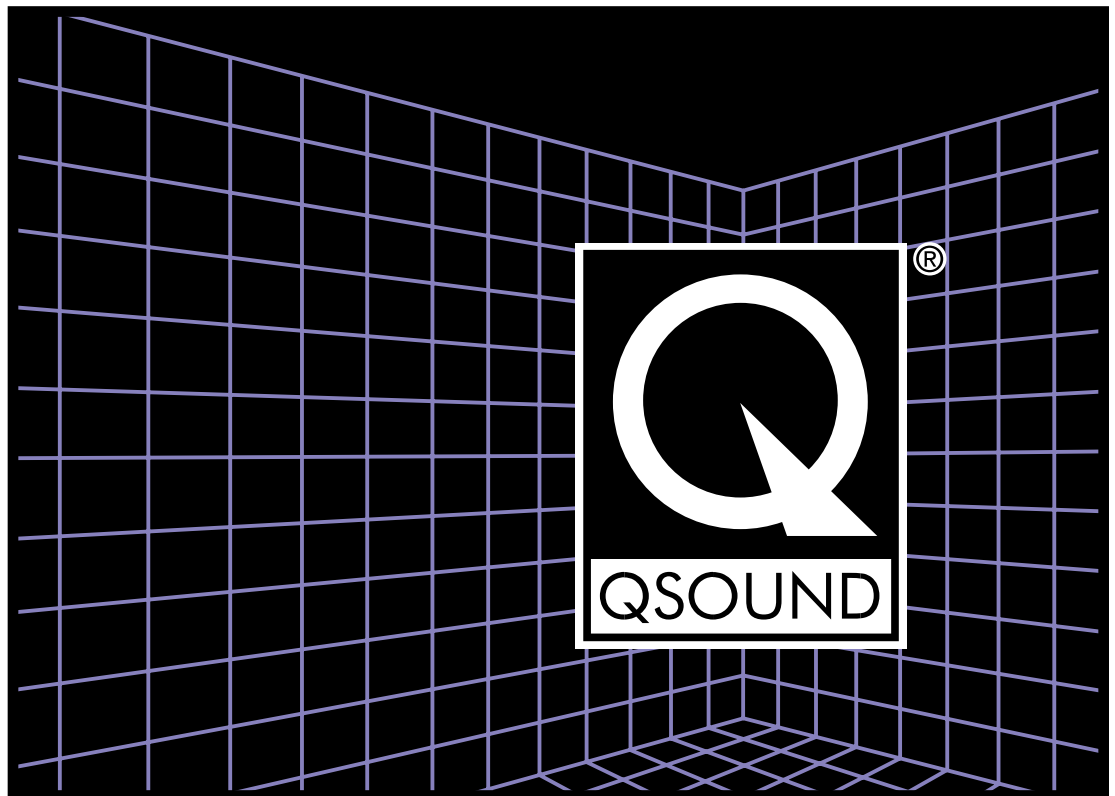

Rev 2.3 01/2008

QSurround®

QSound® Virtual Audio Rendering for Surround Formats

Abstract

This document briefly describes the application of QSound® 3D audio processing in Dolby, DTS, MPEG and other surround playback systems. The unique combination of multi-channel source formats and QSound virtual acoustic imaging provides new possibilities in affordable and upgradeable sound solutions for PC multi-media, portable and home theater systems. Also discussed is a unique surround synthesis algorithm.

Intended Audience

The document is directed primarily to original equipment manufacturers (OEM's). For our purposes this also includes designers of software digital audio tools, operating systems and the like.

A general overview of 3D audio principles and QSound technologies may be found in The OEM Guide to QSound 3DAudio.

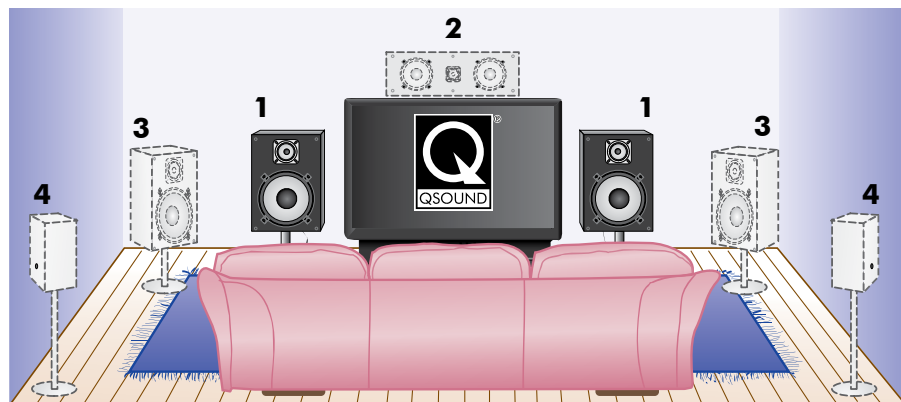

Figure 1. A representation of QSurround virtual surround rendering in 3/2 to 2/0 mode.
1. Actual speakers through which QSurround signal is presented. • 2. Virtual Center speaker.
3. Virtual front fill speakers widen image of front channels. • 4. Virtual Surround speakers.

QSound and Surround Technologies

QSound 3D audio processes, and multi-channel surround technologies, both address the limitations of normal stereo reproduction. QSound 3D audio processes provide the ability to extend the imaging capabilities of *any* physical playback system having at least two discrete output channels. Surround technologies such as DTS, MPEG, Dolby Pro Logic and Dolby Digital (AC-3) provide more than two separate audio channels containing information intended to be reproduced from different physical locations with respect to the listener.

QSurround® capitalizes on the strengths of both systems. This flexible process enables decoded multi-channel surround audio to be reproduced with maximum spatial effectiveness across the entire range of playback systems, from simple stereo to full home theatre.

QSurround renders surround on 2-speaker systems

QSound Labs has years of accumulated expertise in extending the imaging capabilities of standard stereo playback systems. While playback of surround-encoded material over such systems is normally no better than regular stereo, this shortcoming may be dramatically overcome through the use of QSurround processing.

Using only two speakers, the QSurround® process utilizes a phantom center channel, enhances front-channel reproduction, and creates ‘virtual’ surround speakers to render all channels in their correct positions. The expansive sound field created by the QSurround virtual speakers is nothing less than stunning. The audio quality is unmatched in the industry—a direct result of QSound Labs' long history in positional 3D audio technologies for recording professionals.

In addition to the use of separate, purpose-specific virtual image rendering for front and surround channels, QSurround employs a unique mono-to-3D algorithm addressing scenarios having only a mono surround channel (e.g. Dolby Pro Logic) and an entirely different stereo process for formats supporting true stereo surround, such as Dolby Digital.

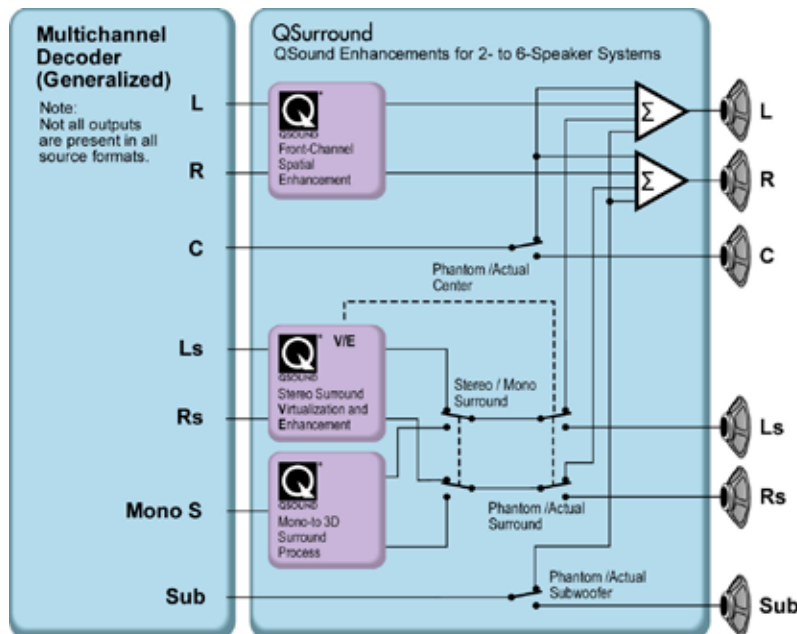

Figure 2. The flexible QSurround process illustrated for up to 5.1 channel output.

QSurround stands apart from competition

It is important to contrast QSurround's sophistication with some overly simple competing technologies. A commonly-employed technique squanders the power of the surround format by reducing it to a stereo mix, to which an overall "stereo widening" algorithm is then applied. The positional separation of surround channel data is destroyed, and proper reproduction of the crucial center channel information will be compromised if the widening algorithm is poor.

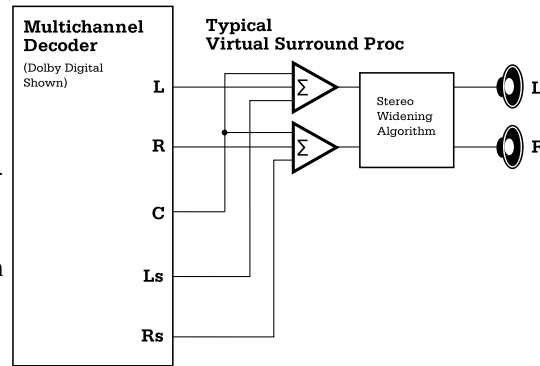

Figure 3. Crude virtual surround process

On the other hand, the QSurround algorithms provide independent processing for each discrete channel to ensure the best reproduction of the surround content irrespective of the number of output channels. The characteristic efficiency of QSound processing provides this top-quality solution within the same resource budget used by some far simpler alternative technologies.

QSurround solutions have been certified by Dolby Laboratories Licensing Corporation for both Dolby Pro Logic and Dolby Digital processes.

Some competitive solutions employ a combination of binaural synthesis (a headphone 3D technology) and crosstalk cancelation. This approach tends to be compute-intensive, unduly sensitive to listening geometry, and characterized by coloration and phase pressure. Since speaker-targeted QSurround implementations are based on the QSound Q3D positional 3D audio process, they are more spectrally accurate and robust, allowing greater flexibility in seating position and speaker placement.

QSurround Enhances Multi-Speaker Systems

Specific QSurround operating modes add value to every arrangement of physical speakers. This flexibility allows QSurround to ease the consumer's introduction to surround formats by providing instant benefit with existing stereo equipment, and a smooth upgrade path to more complex systems if desired. Even on a fully-realized multi-speaker system, QSurround smooths the transition zones between speaker positions for a more realistic, seamless surround sound stage.

QSurround Adapts Surround Formats to Headphones

As previously explained, simple down-mixing of multiple surround channels to stereo squanders the principle advantage of surround formats: multiple source locations.

Furthermore, when listening to any source material on headphones, unless 3D processing is employed, all sound is perceived as being localized (positioned) inside the head, which is unnatural. The three main goals of headphone-targeted 3D processing are:

- to position the apparent location of sounds outside of the head,
- to create the impression of a realistic acoustic environment, and
- to create the perception of unique spatial positions around the listener.

The signal-processing algorithms required for creating 3D effects on headphones are entirely different from those required for loudspeaker playback. There are two

main differences: the direct transducer to ear (TTE) coupling unique to the headphone situation, and room interaction, which is unique to the speaker situation. In turn, room interaction has two main implications: crosstalk (each discrete channel is heard by both ears) and reflections from surfaces which create reverberation—a natural and expected consequence of sound propagation in an enclosed space.

The TTE algorithms QSound Labs has developed enable unprecedented ratios of quality to resource use (code size and memory needs, in digital implementations), but the approach is also highly scalable, providing the optimal solution across a wide variety of platforms, applications, and OEM preferences.

The basic goals of headphone virtualization can be achieved by 3D processing alone, but can be further enhanced by synthesizing a reverberant acoustic environment to provide context, completing the illusion. While there is plenty of room for personal taste when it comes to the application of reverberation, competing algorithms often apply far too much. This tends to provide an initial “wow” factor that quickly wears thin and becomes fatiguing to the listener. When evaluating reverberation in headphone surround, it may be useful to consider whether most listeners would choose to watch a film in a theatre or living room; or in a gymnasium or cave.

Dolby Pro Logic and QSurround

Dolby Pro Logic continues to play an important role in consumer electronics, as legacy formats such as VHS video tape and conventional television broadcasting continue to depend on this encoding method.

QSurround provides effective Pro Logic rendering on any system configuration. Of particular note is the unique surround channel enhancement, which synthesizes a 3D stereo signal from the mono surround channel. QSound’s algorithm is refreshingly free of the sonic anomalies typical of standard mono conversion methods developed in the 1960’s and still used by many vendors today.

QMDV™: Integrated Matrix Decoding and Virtualization

This exclusive QSurround algorithm operates directly on surround content that has been matrix encoded to a stereo-compatible two-channel signal. (This includes digital surround that has been decoded, down-mixed and matrix-re-encoded.)

QMDV performs both passive matrix decoding and surround virtualization. Depending on the specific implementation, the output is two channels (L, R) with virtual center and surround rendering, or three channels (L, C, R) with virtual surround rendering.

In addition to matrix surround decoding/virtualization, QMDV automatically enhances regular stereo signals via the QXpander™ stereo expansion algorithm.

Dolby Digital, MPEG, DTS and QSurround

Dolby Digital (AC-3) surround was adopted as the audio standard by the United States Advanced Television Systems Committee (ATSC) on April 12, 1995. Dolby Digital is also the standard audio delivery format for DVD (Digital Versatile Disc).

In Europe, the MPEG2 data compression format fills a similar role. The DTS system is increasing in popularity world-wide.

Obviously, entertainment audio applications will continue to favor the adoption of multi-channel source formats. Never-the-less, many consumers will continue to resist the expense, complexity and intrusiveness of fully-realized surround systems. QSurround technology bridges the gap, providing significant benefit from the surround content in two-channel playback situations.

QMSS™: QSound Multi-Speaker System

This unique QSound algorithm synthesizes up to five separate outputs from normal stereo or mono input. QMSS is perfect for car audio and multi-speaker portable, home theatre and personal computer surround systems.

In the past, common approaches for the presentation of non-surround content on multi-speaker systems have included simple replication of left and right signals on the rear channels, and replication plus synthesized reverberation in the rear channels.

In both cases, a surround effect of a sort is achieved, but at the expense of image clarity, with less distinct localization of individual components of the stereo signal.

QMSS wraps the stereo image proportionately around the listener across all output channels, with perceptibly separate signals going to each speaker - as though the signal were originally produced in multi-channel surround. An additional benefit is that the studio-quality stereo reverberation typically inherent in recorded music and soundtracks naturally tends to steer to the rear channels. This provides a much improved ambient environment as compared to economically practical consumer aftermarket reverb processors—at no additional cost.

QSurround Implementations

While the data presented herein is as up-to-date as possible, new implementations of QSurround (and other QSound technologies) are constantly under development. Always check with our sales office for the latest product news.

It is important to distinguish between products that provide QSurround *in addition to surround decoding*, and products that provide only QSurround processing.

In addition, some products incorporate a subset of the possible range of QSurround features (e.g. some may only support two outputs, or one surround format.)

Soft DVD

A common approach to decoding the DVD digital data stream on PC's is to use the host processor to handle the audio decoding task, while dedicated hardware processes the video portion of the signal.

QSound offers ports of the QSurround algorithm which run in conjunction with DVD decoding software from multiple vendors. QSurround host code includes optimizations for the Intel® MMX™ instruction set for even better performance.

At present, QSurround is available with soft DVD decoders from **InterVideo**.

Hardware Decoders

QSurround is available on a broad range of hardware surround decoder platforms, as a downloadable algorithm for programmable decoders, and ready-integrated with ROM-based decoder products.

At present, QSurround is available on hardware platforms from manufacturers such as **AKM**, **Crystal Semiconductor**, and **Zoran**. Contact us for current data.

Audio Digital Signal Processors

Many QSurround and QMSS algorithms are available for the **Texas Instruments** eight-channel TAS3108 audio DSP.

QSurround Integrated Circuit Family

The **QS7777** analog IC is available with a choice of two control interfaces (I²S or conventional) and support for all input and output formats. The **QS7777** virtualizes and / or enhances all surround input formats and supports from 2 to 5-channel output. It also allows spatial enhancement of non-surround (i.e. plain mono or stereo) content.

QMSS is available in the form of the **QS7785** surround synthesizer.

Since product lines are continually changing, you are invited to contact us for the most up-to-date information.

For Further Information, Contact:

QSound Labs, Inc.

Head Office: 400, 3115-12 St. NE, Calgary, Alberta, Canada T2E 7J2
Telephone: (403) 291-2492 Facsimile: (403) 250-1521

Email oem.support@qsound.com

Web: <http://www.qsound.com>

While every effort is made to ensure the accuracy of the information presented in this document, QSound Labs cannot be held responsible for the dynamic nature of the marketplace, which may result in changes to product specifications and availability. Please note the revision date below and confirm the currency of all data with QSound Labs, Inc.

© 1998-2008 QSound Labs, Inc.

QXpander, Q2Xpander, Q3D, Q1, Q2, QMDV, QMSS, QSystem, QSurround, QSound and the QSound logo are trademarks of QSound Labs, Inc. Other product names are the trademarks of their respective companies.

Rev 2.3 01/2008